



SERVICE INFORMATION LETTER 26-13

SCOPE

This Service Information Letter covers the disposal of pyrotechnic cartridges manufactured by MASS Systems.

CARTRIDGE DISPOSAL

WARNING: THE CARTRIDGE MUST BE DETONATED IN A SAFETY FIXTURE THAT PROTECTS PERSONNEL FROM SERIOUS INJURY.

1. Ground the cartridge safety chamber.
2. Wrap the ground strap around your wrist and connect the ground strap to the circuit tester. Test the ground circuit.

WARNING: THE CARTRIDGE IS AN EXPLOSIVE DEVICE. FOR SAFE HANDLING, PERSONNEL MUST BE GROUNDED AND A SHUNT DEVICE MUST BE INSTALLED ON THE CARTRIDGE. INADVERTENT DETONATION OF A CARTRIDGE MAY CAUSE INJURY.

3. Make sure the shunt device and the o-ring are installed on the cartridge.
4. Thread the cartridge into the cartridge safety chamber.
5. Remove the shunt device and connect the power supply. Stand back five-feet (1,5 meters) minimum and apply 28-VDC, 3.5-AMPERES MINIMUM to detonate the cartridge.
6. Remove the detonated cartridge from the cartridge safety chamber and discard in accordance with approved procedure.

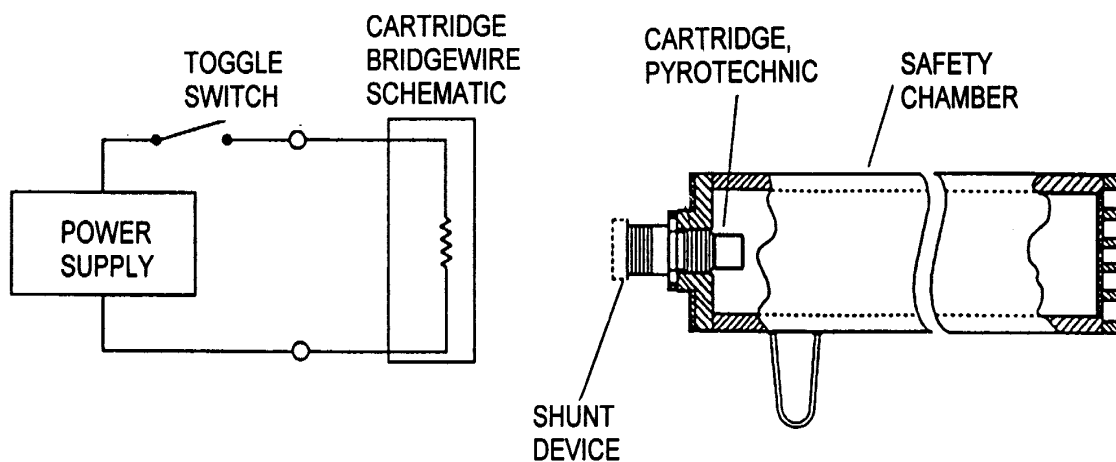

Cartridge Disposal Setup